



9800 Martel Road
 Lenoir City, TN 37772
www.ps-engineering.com

PAC24
Audio Control Panel and Intercom System
For Special Applications



050-240-0123



050-240-0700

Installation
and
Operation Manual
FAA-Approved TSO C50c
JAA-Approved JTSO C50c

Document P/N 200-240-0123
 Rev. 2 May 2019

In certified aircraft, warranty is not valid unless this product is installed by an Authorized PS Engineering dealer.

PS Engineering, Inc. 2019 ©
Copyright Notice
 Any reproduction or retransmittal of this publication, or any portion thereof, without the expressed written permission of PS Engineering, Inc. is strictly prohibited. For further information contact the Publications Manager at PS Engineering, Inc., 9800 Martel Road, Lenoir City, TN 37772. Phone (865) 988-9800, email info@ps-engineering.com.

Table of Contents

<u>SECTION I GENERAL INFORMATION.....</u>	<u>1-1</u>
1.1 INTRODUCTION.....	1-1
1.2 SCOPE.....	1-1
1.3 EQUIPMENT DESCRIPTION.....	1-1
1.4 APPROVAL BASIS -	1-2
1.5 SPECIFICATIONS.....	1-2
1.6 EQUIPMENT SUPPLIED.....	1-3
1.7 EQUIPMENT REQUIRED BUT NOT SUPPLIED.....	1-4
1.8 LICENSE REQUIREMENTS.....	1-4
<u>SECTION II - INSTALLATION.....</u>	<u>2-1</u>
2.1 GENERAL INFORMATION.....	2-1
2.1.1 SCOPE.....	2-1
2.1.2 UNPACKING AND PRELIMINARY INSPECTION.....	2-1
2.2 SYSTEM CONFIGURATION	2-1
2.2.1 DISASSEMBLY AND ACCESS.....	2-1
2.2.2 SINGLE/DUAL CONFIGURATION JUMPERS J4 & J5.....	2-3
2.2.3 DIP SWITCH CONFIGURATIONS.....	2-4
2.2.4 PASSENGER AND EXPANSION DIP SWITCH CONFIGURATIONS.....	2-4
2.2.5 DIP SWITCH CROSS REFERENCE.....	2-6
2.3 EQUIPMENT INSTALLATION PROCEDURES.....	2-7
2.3.1 MOUNTING REQUIREMENTS.....	2-7
2.3.2 COOLING REQUIREMENTS.....	2-7
2.3.3 MOUNTING RACK INSTALLATION.....	2-8
2.3.4 TRAY AND CONNECTOR ASSEMBLY.....	2-8
2.4 CABLE HARNESS WIRING.....	2-8
2.4.1 NOISE.....	2-8
2.4.2 POWER.....	2-9
2.4.3 COMMUNICATIONS PUSH-TO-TALK (SINGLE PANEL INSTALLATION).....	2-9
2.4.4 AUDIO PANEL INTERFACE.....	2-9
2.4.5 TRANSMIT INTERLOCK.....	2-9
2.4.6 BACKLIGHTING.....	2-9
2.4.7 UNSWITCHED INPUTS.....	2-9
2.4.8 PA MUTE (J3, PIN 8).....	2-10
2.4.9 PUBLIC ADDRESS (J3, PIN B).....	2-10
2.4.10 INTERCOM WIRING.....	2-10
2.4.11 ENTERTAINMENT INPUT (J3 PIN 7).....	2-10
2.4.12 INTERCOM EXPANSION (P/N 11606 OR 11606R).....	2-11
2.4.13 CVR OUTPUT.....	2-11
2.5 ADJUSTMENTS.....	2-11
2.6 COMMUNICATIONS ANTENNA INSTALLATION NOTES.....	2-12
2.7 POST INSTALLATION CHECKOUT.....	2-12
2.8 UNIT INSTALLATION.....	2-12
2.8.1 OPERATIONAL CHECKOUT.....	2-12
2.9 FINAL INSPECTION.....	2-13
<u>SECTION III OPERATION.....</u>	<u>3-1</u>
3.1 SCOPE.....	3-1
3.2 PAC24 CONTROLS.....	3-1

3.3 POWER SWITCH (3) (EMG-FAIL SAFE OPERATION)..... 3-2
3.3.1 SINGLE PANEL FAIL SAFE OPERATION..... 3-2
3.3.2 DUAL PANEL FAIL SAFE OPERATION 3-2
3.4 COMMUNICATIONS SELECTION (2)..... 3-2
3.4.1 STUCK MICROPHONE PROTECTION 3-2
3.5 RECEIVE AUDIO SELECTOR (1)..... 3-2
3.5.1 SPEAKER AMPLIFIER (4) 3-3
3.5.2 KEY “CLICK” 3-3
3.6 SPLIT MODE 3-3
3.6.1 SPLIT MODE, DUAL PANEL..... 3-3
3.7 INTERCOM OPERATION 3-3
3.7.1 *INTELLIVOX*® VOX-SQUELCH..... 3-3
3.7.2 VOLUME CONTROL (3) 3-4
3.7.3 INTERCOM MODES (5) 3-4
3.7.4 ENTERTAINMENT INPUT 3-5

SECTION IV- WARRANTY AND SERVICE..... 4-1
4.1 WARRANTY..... 4-1
4.2 FACTORY SERVICE..... 4-1

APPENDIX A – INSTALLATION DRAWINGA
APPENDIX B SINGLE UNIT STANDARD INTERCONNECT WIRING.....B
APPENDIX B DUAL INTERCONNECT RADIO WIRING (-0123 UNITS)B
7.1 DUAL PAC24 CREW AUDIO WIRING, STANDARD (-0123, -8278) UNITSB

APPENDIX C- INSTRUCTIONS FOR FAA FORM 337 AND CONTINUING
AIRWORTHINESSC
8.1 INSTRUCTIONS FOR FAA FORM 337, AUDIO PANELS.....C
8.2 INSTRUCTIONS FOR CONTINUING AIRWORTHINESS, AUDIO PANELSC

APPENDIX D – RTCA DO160D (EUROCAE ED-14) ENVIRONMENTAL
QUALIFICATION FORM.....D

Rev	Date	Change
New		Release Special versions, 050-240-0123
1	December 2016	Change COM 3 to HF Button nomenclature
2	May 2019	Add new special version, 050-240-0700

Section I GENERAL INFORMATION

1.1 INTRODUCTION

The PAC24 represents the finest in high-performance cockpit audio control and intercommunications. Using proprietary *IntelliVox*® design, this unit eliminates the requirements for intercom squelch adjustments. The unit is designed for outstanding ergonomics and visually defined mode annunciation and selection.

The PAC24 was designed as either a single or a dual audio panel system.

Before installing and/or using this product, please read this manual completely. This will ensure that you will take full advantage of all the advanced features in the PAC24.

1.2 SCOPE

This manual provides detailed installation and operation instructions for the PS Engineering PAC24-series of Audio Selector Panel/Intercom Systems. This includes the following units:

Model	Description	Part Number
PAC24	Audio Selector with Intercom, Special version with dual ADF nomenclature (single or dual installation)	050-240-0123
PAC24	Audio Selector with Intercom, Special version with four COMs ADF, DME and MKR nomenclature. (Can replace KMA 24H-70)	050-240-0700

Where the functions are identical to all units, it will be referred to herein as a PAC24. Otherwise, the applicable units will be specified.

1.3 EQUIPMENT DESCRIPTION

The PAC24-series is a state of the art audio isolation amplifier and audio selector that contains an automatic voice activated (VOX) intercom system. It can switch up to four transceivers (-0123, COM 1, COM 2 HF) and 6 receivers (NAV 1, NAV 2, ADF 1 and ADF 2 DME and MKR)(-0700 COM 1, COM 2, COM 3, COM 4, NAV 1, NAV 2, DME, ADF, MKR)

- Three or four transceivers
- Split mode in single audio panel installation
- Six switched receivers
- Two Unswitched inputs
- Speaker amplifier
- Separate Public Address output
- Push-button control with LED indication
- Intercom with Pilot Isolate and ALL mode (Crew mode with expansion unit)
- Monaural music input with SoftMute™

A fail-safe mode connects the pilot headphone and microphone to COM 1 if power is removed for any reason, or if the power switch is placed in the Off (Fail-safe) position.

A voice activated (VOX) intercom is included in the PAC24. This system has PS Engineering's exclusive *IntelliVox*® circuitry that eliminates manual adjustments. The system contains five independent VOX mic circuits, and only opens the specific microphone channel in use.

The intercom system incorporates pilot isolate (ISO) and ALL modes. A crew mode is ONLY available with external expansion module P/N 11606.

A dual volume controls intercom level for the pilot, inner knob, and copilot/passengers (outer knob). Intercom squelch is automatic.

1.4 APPROVAL BASIS -

FAA-TSO Approval.

The PAC24 Audio Selector Panels are FAA approved under TSO C50c (Audio Amplifiers). In addition, the PAC24 is JAA-JTSO approved under LBA.N-O.10.510/003JTSO.

All systems comply with relevant portions of EUROCAE ED-14C/DO-160D (*Environmental Conditions and Test Procedures for Airborne Equipment*), ED12B/DO-178B (*Software Considerations for Airborne Equipment*) and ED-18/DO-214 (*Audio Systems Characteristics and Minimum Operational Performance Standards for Aircraft Audio Systems*).

Operation is subject to the following conditions:

This device may not cause harmful interference.

This device must accept any interference received, including interference that may cause undesired operation.

1.5 SPECIFICATIONS

TSO COMPLIANCE	
<i>Audio Selector/Intercom:</i>	C50c, Class A
APPLICABLE DOCUMENTS:	RTCA/DO-214 RTCA/DO-160D RTCA/DO-178B
ENVIRONMENTAL Qualifications:	B1ZCABSRXXXXXXXXZBBBATMXXE2XXX
<i>Temperature Range:</i> Operating: Storage:	-20°C to +55°C with short term operating at +70°C -55°C to +85°C
<i>Altitude:</i>	Up to 50,000 feet in a non-pressurized area of the cockpit.
DIMENSIONS:	Height: 1.3 in. (3.3 cm) Width: 6.25 in. (16.9 cm) Depth: 6.8 in. (17.3 cm) behind panel
WEIGHT (With Rack & Connectors):	1.5 lb. (0.54 kg)

PS Engineering
PAC24 Series Audio Selector Panel and Intercom System
Installation and Operator's Manual

Specifications, Continued.

POWER REQUIREMENTS (Including Internal Lighting):	
<i>Voltage:</i>	11 to 33 VDC
<i>Maximum Current:</i>	2.5 Amp (Externally protected by a 3 Amp circuit breaker.)
<i>Typical operating current:</i> Speaker off:	350 mA
Speaker on, 28V, full radio volume	1.5 A
Audio Selector Specifications	
<i>Audio selector panel input impedance:</i>	510 Ω
<i>Input Isolation:</i>	-60 dB (min.)
<i>Speaker Muting:</i>	-60 dB (min.)
<i>Speaker Output</i> (into 4 Ω) with no clipping 14 VDC:	3 Watts (min.)
28 VDC:	10 Watts (min.)
<i>Receiver Inputs:</i> 050-240-0123	10 (COM 1, COM 2, HF, NAV 1, NAV 2, ADF1, ADF 2, DME, MKR)
050-240-0700	9 (COM 1, COM 2, COM 4, NAV 1, NAV 2, DME ADF, MKR)
<i>Unswitched Inputs:</i>	2 (examples: GPS WPT, Value, Autopilot Disconnect, Altimeter DH)
<i>Transmitter Selections:</i>	5 (COM 1, COM 2, HF)
<i>Speaker Impedance:</i>	4 – 8 Ω
<i>Headphone Impedance:</i>	150 – 1000 Ω
<i>Headphone Output:</i>	38 mW each headset, no clipping <1% THD 120 mW each headset with < 10% THD into 150 Ω
<i>Microphone Impedance:</i>	150 - 600 Ω
Intercom Specifications	
<i>Intercom Positions:</i>	Minimum of 5 places (with individual <i>IntelliVox</i> ® circuits)
<i>Music Input:</i>	1 (Monaural)
<i>Music Muting:</i>	>-30 dB "Soft Mute" when Com or intercom active.
<i>Distortion:</i>	<1% THD @ 38 mW into 150 Ω <10% THD @ 120mW into 150 Ω
<i>Mic Freq. Response, 3 dB:</i>	300 Hz - 6000 Hz
<i>Music Freq. Response, 3 dB:</i>	100 Hz - 18kHz

1.6 EQUIPMENT SUPPLIED

1 ea. of the following units:

Model	Description	Part Number
PAC24	PAC24 Audio Control Panel with intercom with Dual ADF	050-240-0123
PAC24	PAC24 Audio Control Panel with intercom, four COMS	050-240-0700

PS Engineering
PAC24 Series Audio Selector Panel and Intercom System
Installation and Operator's Manual

PAC24 Installation Kit: 250-240-0001

Description	Quantity	Part Number
PAC24 installation rack assembly	1	475-240-0040
Molex Connector Shell w/key, 50 pin, key 17/18	1	120-425-5002
Gold Plated Crimp Pins	42	425-001-0002
4 40 X 7/16 screw w/nylon patch	4	475-440-0007
Grounding bar	1	430-007-0001
6-32 X 3/4 pan head Phillips screw	2	475-632-0038
6-32 Nut Flat	2	475-632-0003
6-32 Lock Nut	2	475-632-0004
Cable Clamp	1	625-001-0002
#6-32 x 1/2" Flat head Phillips screw	6	475-632-0012
#6-32 Clip Nut	6	475-630-0002
Parts identification sheet	1	002-250-0240

1.7 EQUIPMENT REQUIRED BUT NOT SUPPLIED

- a) Circuit Breaker: 1 ea. 3 amp
- b) Cockpit Speaker, 4 Ω recommended
- c) Cabin or External Speaker 4 Ω recommended
- d) Headphone Jacks (as required)
- e) Microphone Jacks (as required)
- f) Headphones, 150 Ω as required
- g) Microphones, as required
- h) Interconnect Wiring

1.8 LICENSE REQUIREMENTS

None

Section II - Installation

2.1 GENERAL INFORMATION

2.1.1 SCOPE

This section provides detailed installation and interconnect instructions for the PS Engineering PAC24-Series Audio Control Panel/Intercom System.

Please read this manual carefully before beginning any installation to prevent damage and post-installation problems. Installation of this equipment requires special tools and knowledge.

NOTE: The PAC24 requires specialized knowledge and tools for an effective installation. An appropriately rated Certified Aircraft Repair Station **must** install this equipment in accordance with applicable regulations. PS Engineering, Incorporated warranty is not valid unless the equipment is installed by an authorized PS Engineering, Incorporated dealer. Failure to follow any of the installation instructions, or installation by a non-certified individual or agency will void the warranty, and may result in an **unairworthy** installation.

2.1.2 Unpacking and Preliminary Inspection

Use care when unpacking the equipment. Inspect the units and parts supplied for visible signs of shipping damage. Examine the unit for loose or broken buttons, bent knobs, etc. Verify the correct quantity of components supplied with the list in Section 1.6 (B). If any claim is to be made, save the shipping material and contact the freight carrier. Do NOT return units damaged in shipping to PS Engineering. If the unit or accessories shows any sign of external shipping damage, contact PS Engineering to arrange for a replacement. Under no circumstances attempt to install a damaged unit in an aircraft. Equipment returned to PS Engineering for any other reason should be shipped in the original PS Engineering packaging, or other UPS approved packaging.

2.2 System Configuration



The PAC24 can be easily configured for many different applications. This includes dual audio panel installations.

The information below describes the various circuit jumper configurations and internal switch selections. There are two sections, the first explains what each switch does, and the second is a list of specific configurations. For more information, consult [PAC24 Configuration Quick Reference Guide, document number 200-240-0310](#).

In a single installation, with no options, *no action is required*.

In dual installations, place the DIP switches into the proper position to configure the PAC24 as the pilot, or copilot panel.

By designating a pilot or copilot panel, the aircraft commander, or pilot, will have priority for transmissions and intercom mode selection.

Note:

Bold=Default settings (as shipped from factory)

Units are shipped as single unit configuration, 28V lighting.

PAC24 units **MUST** be reconfigured before any *other* configuration is used.

2.2.1 Disassembly and access

To access the circuit jumpers and DIP switches, remove the top cover by removing the two (2) screws at the sides holding the cover in place.

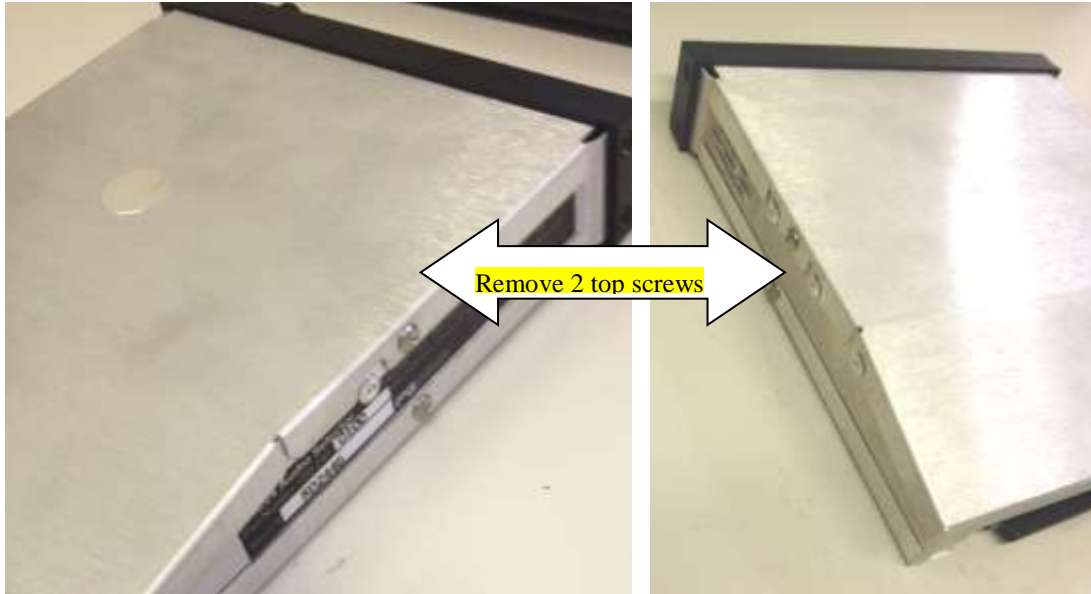

Figure 2-1 Cover Screw Locations

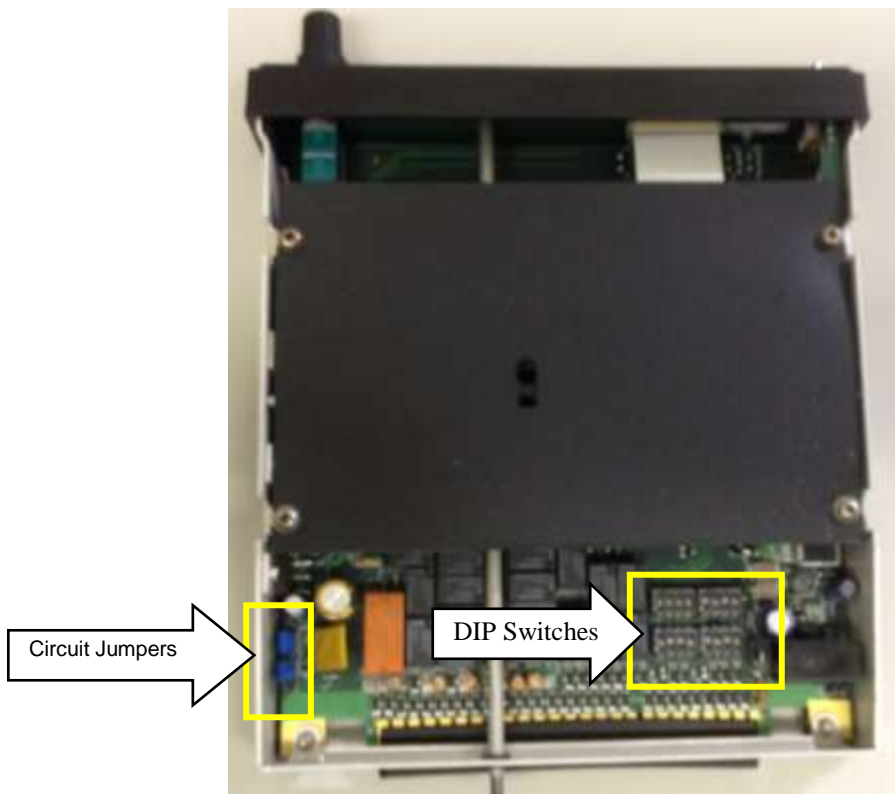

Figure 2-2 Locations

2.2.2 Single/Dual configuration jumpers J4 & J5

Single System or Pilot Audio Panel	Copilot Audio Panel
J4 ON (installed)	J4 OFF (Removed)
J5 Jumper Pins 1 & 2	J5 Jumper Pins 2 & 3

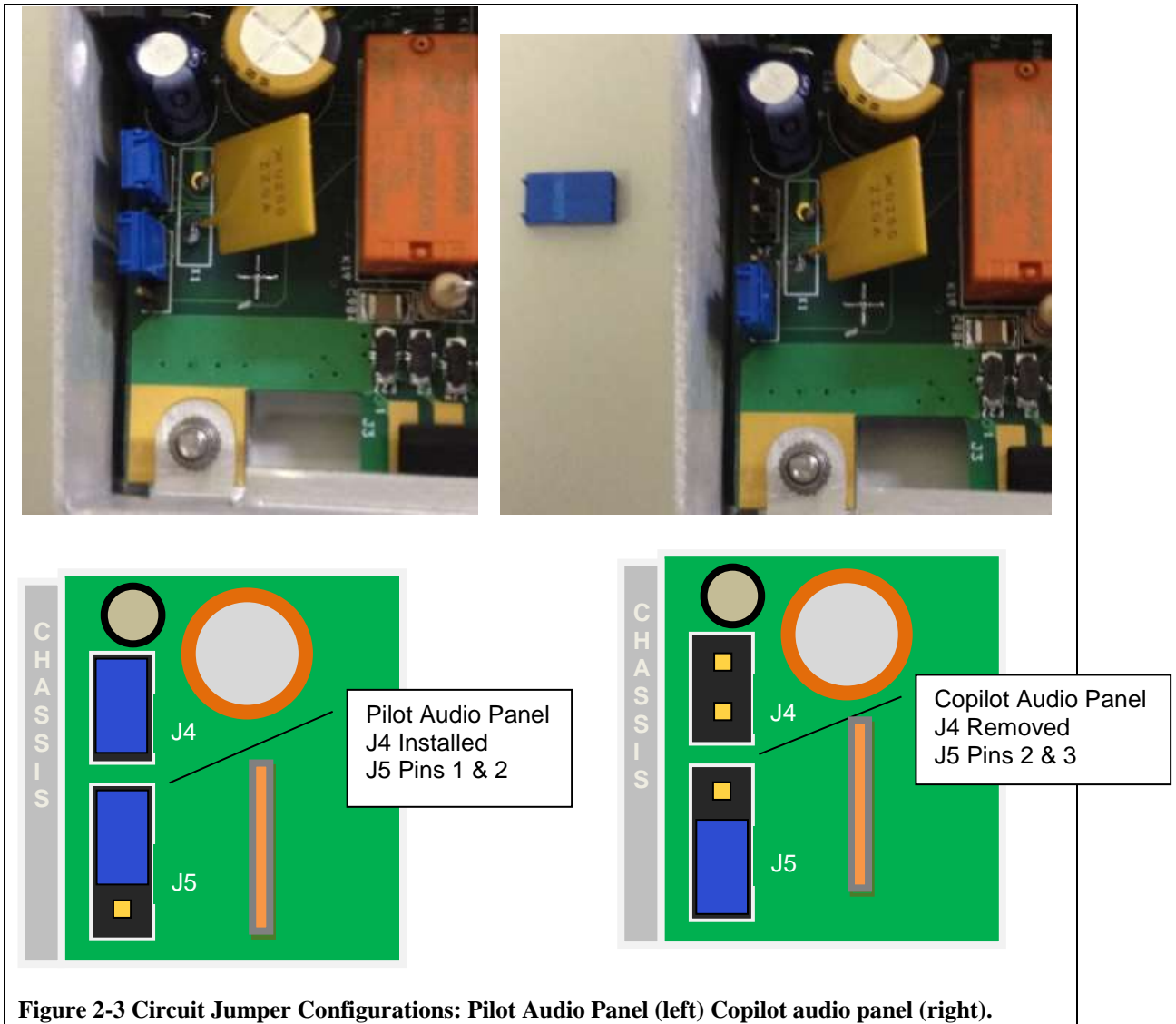

Figure 2-3 Circuit Jumper Configurations: Pilot Audio Panel (left) Copilot audio panel (right).

2.2.3 DIP Switch Configurations

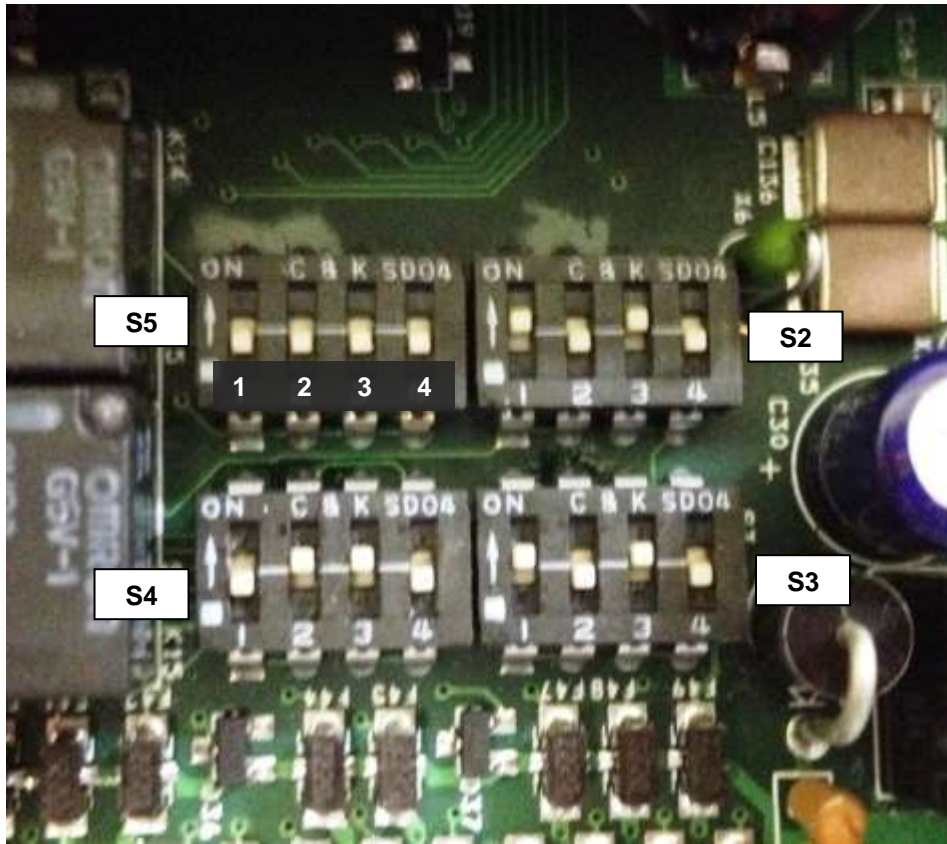

Figure 2-4 DIP Switch positions

2.2.3.1 Pilot/Copilot Audio Panel DIP Switch Configuration

Switch	S5					
2	OFF	Single PAC24 Installation	ON	Pilot unit –Dual Installation	ON	Copilot unit – Dual Installation
3	OFF		OFF		ON	

Table 2-1 Pilot/Copilot Dual Panel Selection Switch (S5)

2.2.4 Passenger and Expansion DIP Switch Configurations

2.2.4.1 Pass 3 / Expansion (P/N 11606) – J3, pin a configuration (S2)

As shipped, the PAC24 is 5-place intercom, and the ability to convert the system from a 5-place intercom to use an expansion unit that will allow up to 8 places on the intercom per audio panel.

Switch	S2			
3	ON	Pass 3 Mic Input	OFF	P/N 11606 Expan- sion Power out
4	OFF		ON	

PS Engineering
PAC24 Series Audio Selector Panel and Intercom System
Installation and Operator's Manual

2.2.4.2 Pass 1 / Expansion (P/N 11606) – J3, pin 22 configuration (S2)

Switch	S3			
1	ON	Pass 1 mic input	OFF	P/N 11606 Expansion audio input
2	OFF		ON	

2.2.4.3 Pass 2 / Expansion (P/N 11606) - J3, pin 23 configuration (S3)

Switch	S3			
3	ON	Pass 2 mic input	OFF	P/N 11606 Expansion audio output
4	OFF		ON	

2.2.4.4 CVR – J3, pin 2 configuration (S2)

Cockpit Voice Recorder audio output connector pin 2

Switch	S2			
1	ON	CVR Output	OFF	OPEN
2	OFF		ON	

2.2.4.5 14-Volt Backlighting – J3, pin 18 configuration (S4)

Switch	S4			
1	ON	14 V lighting control	OFF	Swap switch
2	OFF		ON	

2.2.4.6 28-Volt Backlighting – J3, pin U configuration (S4)

Switch	S4			
3	ON	28 V lighting control	OFF	Swap switch
4	OFF		ON	

2.2.4.7 Backlight 14/28V

Switch	14 V	28V
1	On	Off
2	Off	On
3	Off	On
4	On	Off

14 V Aircraft	28 V aircraft
Pin 18= 14 V input	Pin 18=Swap
Pin U=Swap	Pin U =28 V input

2.2.5 DIP Switch Cross reference.

Single Installation- 28 Volt Aircraft					Single panel with Expansion (P/N 11606) 28 Volt Aircraft				
	SW2	SW3	SW4	SW5		SW2	SW3	SW4	SW5
1	ON	ON	OFF	OFF	1	OFF	OFF	OFF	ON
2	OFF	OFF	ON	OFF	2	ON	ON	ON	OFF
3	ON	ON	ON	OFF	3	OFF	OFF	ON	OFF
4	OFF	OFF	OFF	See notes	4	ON	ON	OFF	See notes
J4- On/ J5- Pins 1 & 2					J4- On/ J5- Pins 1 & 2				

Table 2-2 Single Audio Panel DIP switch settings

Dual PAC24 - Pilot Panel- 28 Volt Aircraft					Dual PAC24- Copilot Panel- 28 Volt Aircraft				
	SW2	SW3	SW4	SW5		SW2	SW3	SW4	SW5
1	ON	ON	OFF	OFF	1	ON	ON	OFF	OFF
2	OFF	OFF	ON	ON	2	OFF	OFF	ON	ON
3	ON	ON	ON	OFF	3	ON	ON	ON	ON
4	OFF	OFF	OFF	See notes	4	OFF	OFF	OFF	See notes
J4- On/ J5- Pins 1 & 2					J4- Off J5- Pins 2 & 3				

Table 2-3 Dual Audio Panel DIP Switch Settings without expansion

Dual PAC24 with Expansion (P/N 11606)- Pilot Panel- 28 Volt Aircraft					Dual PAC24 with Expansion (P/N 11606)- Copilot Panel- 28 Volt Aircraft				
	SW2	SW3	SW4	SW5		SW2	SW3	SW4	SW5
1	ON	ON	OFF	ON	1	ON	ON	OFF	ON
2	OFF	OFF	ON	ON	2	OFF	OFF	ON	ON
3	OFF	OFF	ON	OFF	3	OFF	OFF	ON	ON
4	ON	ON	OFF	See notes	4	ON	ON	OFF	See notes
J4- On/ J5- Pins 1 & 2					J4- Off/ J5- Pins 2 & 3				

Table 2-4 Dual Audio Panel DIP Switch Settings with expansion

PS Engineering
PAC24 Series Audio Selector Panel and Intercom System
Installation and Operator's Manual

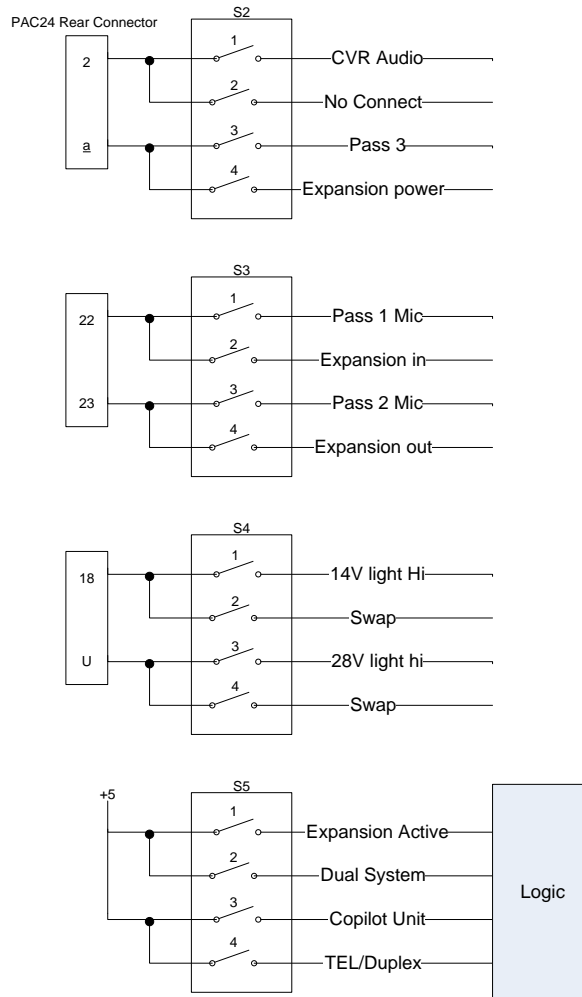

Figure 2-5 DIP switches shown schematically

General Notes

- For 14V aircraft, change SW4 1-4 to ON, OFF, OFF, ON
- For CVR output, change SW2 1-2 to ON, OFF. NOTE: IRS cannot be used

2.3 Equipment Installation Procedures

2.3.1 Mounting Requirements

The PAC24 must be rigidly mounted to the instrument panel of the aircraft structure and within view and reach of the pilot position(s). Installation must comply with FAA Advisory Circular AC 43.13-2A. The unit may be mounted in any area where adequate clearance for the unit and associated wiring bundle exist.

Avoid installing the audio panel close to high current devices or systems with high-voltage pulse type outputs, such as DME or transponders.

NOTE: The mounting hole configuration for the PAC24 is identical to the KMA-24H -71 Audio Selector Panels.

2.3.2 Cooling Requirements

Forced air cooling of the PAC24 is not required. However the unit should be kept away from heat producing sources (i.e. defrost or heater ducts, dropping resistors, heat producing avionics) without adequate cooling air provided. Outside, ram air cooling of the unit is not permitted, and may result in damage.

2.3.3 Mounting Rack Installation

Remove the unit from the mounting tray by unscrewing the 3/32" hex-head screw that is between the RCV and XMT legends. Use caution to avoid hitting the photo-detector lens. Carefully slide the unit free of the tray. Set the unit aside in a safe location until needed. Install the tray using six clip nuts (475-630-0002), and six FHP 6-32 x 1/2" screws (475-632-0012). The audio selector panel must be supported at front and rear of the mounting tray.

2.3.4 Tray and Connector Assembly

The unit connector mates directly with the circuit board in the PAC24. The connector is a Molex crimp-type, and requires the use of a Molex hand crimp tool, EDP P/N 11-01-0203, CR6115B (or equiv.). The connector is mounted to the unit tray with #4-40 screws (475-440-0007), from the inside of the tray. Ensure that proper strain relief and chafing precautions are made during wiring and installation, using the cable clamp (625-001-0002). Secure the ground bar (430-630-0002), if desired using, #6-32 nuts (475-632-0003) and #6-32 lock nuts (475-632-0004).

2.4 Cable Harness Wiring

Referring to the appropriate Appendix, assemble a wiring harness as required for the installation. All wires must be MIL-SPEC in accordance with current regulations. Two- and three-conductor shielded wire must be used where indicated, and be MIL-C-27500 or equivalent specification. Proper stripping, shielding and soldering technique must be used at all times. It is imperative that correct wire be used.

Refer to FAA Advisory Circular 43.13-2A for more information. Failure to use correct techniques may result in improper operation, electrical noise or unit failure. Damage caused by improper installation will void the PS Engineering warranty.

2.4.1 Noise

Due to the variety and the high power of radio equipment often found in today's general aviation aircraft, there is a potential for both radiated and conducted noise interference.

The PAC24 power supply is specifically designed to reduce conducted electrical noise on the aircraft power bus by at least 50dB. Although this is a large amount of attenuation, it may not eliminate all noise, particularly if the amplitude of noise is very high. There must be at least 13.8 VDC present at the bottom connector, pin 25, of the PAC24 for the power supply to work in its designed regulation. Otherwise, it cannot adequately attenuate power line noise. Shielding can reduce or prevent radiated noise (i.e., beacon, electric gyros, switching power supplies, etc.) However, installation combinations can occur where interference is possible. The PAC24 was designed in a RFI hardened chassis and has internal Electromagnetic Interference (EMI) filters on all inputs and outputs.

Ground loop noise occurs when there are two or more ground paths for the same signal (i.e., airframe and ground return wire). Large cyclic loads such as strobes, inverters, etc., can inject noise signals onto the airframe that are detected by the audio system. Follow the wiring diagram very carefully to help ensure a minimum of ground loop potential. Use only Mil Spec shielded wires (MIL-C-275000, or better). Under no circumstances combine a microphone and headphone wiring into the same shielded bundle. Always use a 2- or 3-conductor, shield wire as shown on the installation wiring diagram.

Radiated signals can be a factor when low level microphone signals are "bundled" with current carrying power wires. Keep these cables physically separated. It is very important that you use insulated washers to isolate the ground return path from the airframe to **all** headphone and microphone jacks.

Adding a high-performance audio control system, particularly in conjunction with high-performance active noise canceling headsets, cannot improve on older avionics that were designed for cabin-speaker use. PS Engineering makes no claim that the audio panel will provide a noise-free audio quality under all installation conditions, particularly with older avionics.

2.4.2 Power

The PAC24-Series are compatible with both 14 and 28 Volt DC systems. A three (3) Amp breaker is required. Power and ground wires must be a #18 AWG pair. Connect airframe power ground to J3 Pin 25 only. No dropping resistors are required.

2.4.3 Communications Push-to-Talk (single panel installation)

Unless the system is in split mode, only the person who presses their transmit PTT switch will be heard over the radio. If the pilot and copilot both use the PTT, only the pilot position has access to the radio. The pilot position will have PTT control regardless of the copilot PTT when the PAC24 is in the OFF/EMG mode.

2.4.3.1 Communications Push-to-Talk (Dual Panel Installation)

The PAC24 automatically senses if the other audio panel is transmitting. If communications transceivers selected for transmit are different (COM 1 pilot, TAC 1 copilot), both panels will allow simultaneous, dual transmission (split mode). If the *same* radio has been selected for transmit on *both* audio panels, the pilot mic will have priority, and the copilot will not transmit.

2.4.4 Audio Panel interface

The PAC24 is designed to interface with standard aircraft avionics, and presents a 500Ω receiver impedance. For best results, a twisted-shielded cable is recommended from the avionics audio source to the audio panel, with the shield grounded at the audio panel end.

Some avionics do not provide a separate audio low, and may introduce additional electrical noise into the system. For best results, connect the audio low from the audio panel to the radio ground, using one conductor of the twisted-shielded cable.

2.4.5 Transmit Interlock

Some communications transceivers use a transmit-interlock system. To fully utilize the Split Mode feature, this function must be disabled. Consult that manufacturer's installation manual.

2.4.6 Backlighting

The PAC24 has an automatic dimming of the pushbutton annunciator LEDs and marker lamps controlled by a photocell. Control of the unit backlighting is through the aircraft avionics dimmer. Connect the dimmer control line to J3 pin 18 for 14-volt systems, and to J3 pin U for 28-volt systems. Pin 17 is light ground.

If an external dimmer control is not used, a constant low-level back light illumination can be established for nighttime viewing. Pin 18 or U (depending on system voltage) must be tied to power (J3, pin 25) for the back lighting system to work. The photocell mounted in the unit face will automatically adjust the intensity of the push-button annunciator LEDs.

2.4.7 Unswitched inputs

J3, pin 10 is the unswitched input number 1 and J3 pin 14 is unswitched input 2. These inputs are presented to the pilot and copilot regardless of the audio configuration, and will always mute the entertainment inputs. These 510Ω inputs can be used for altimeter DH audio, GPS waypoint audio, autopilot disconnect tones, or any other critical audio signal.

NOTE: In installations where an expansion unit is NOT used, the passenger and copilot audio output is paralleled (J1, pin b). Therefore, unswitched audio will be heard by the passenger(s). Use an expansion unit, P/N 11606, or 11606R (remote) to isolate passenger audio from unswitched alert audio.

2.4.8 PA Mute (J3, Pin 8)

Pin 18 of J3 is a TTL logic output that is pulled low during PTT operation. This serves as an input to external public address system to prevent feedback during transmissions.

2.4.9 Public Address (J3, Pin B)

When the Speaker mode switch is in the PA mode, and the pilot's PTT is activated, his voice is heard over the PA speaker output on J3, Pin B. The copilot can continue to use the selected com.

In a dual installation, both the pilot and copilot panels can be connected to separate PA Speakers, for instance, one ramp hailer, and one public address speaker.

NOTE: Connecting two audio panels to a single speaker for cockpit and/or cabin address can result in damage to the audio panel.

2.4.10 Intercom wiring

See Appendices for intercom connection configurations. It is critical to the proper operation of this system to have this connector wiring made in accordance with these diagrams. Use 2- and 3-conductor, MIL-spec cable as shown. Connect the shields at the audio panel end only, and tie to the audio low inputs as shown.

2.4.10.1 Push to talk intercom

The PAC24 can be used as an IntelliVox® intercom, or, as a keyed intercom. Switching J3 pin W to ground will inhibit the IntelliVox® and the intercom squelch will not open until the ICS PTT switch is activated.

The following pins are used to control the intercom when PTT ICS is desired. Pin 11 must be grounded through a momentary switch for the pilot to talk on the intercom (with W also grounded). Pin M must be grounded through a momentary switch for the copilot to talk on the intercom (with W also grounded).

2.4.11 Entertainment Input (J3 Pin 7)

If music or entertainment is desired, a monaural input can be applied to Pin 7 of J3.

NOTE: Use the low level output of any entertainment device to connect to the audio panel. Maximum signal level is **2 VAC** p-p.

DO NOT use a speaker-level output, this will cause internal damage in the audio panel.

All entertainment devices must be switched **off** for both takeoff and landing.

2.4.11.1 Entertainment distribution

The entertainment source provides music for all intercom positions. In ISO, it is removed from the pilot. The PAC24-system incorporates a "Soft Mute" system. This will mute the entertainment devices during ICS or radio conversation.

Any signal appearing in the unswitched audio inputs will always mute the entertainment sources, even though the passengers may not hear the audio tone itself.

Caution: Local oscillators and internal signals from some entertainment equipment can cause undesired interference with other aircraft systems. Before takeoff, operate the entertainment devices to determine if there is any adverse effect within the aircraft systems. If any unusual operation is noted in flight, immediately switch off the entertainment devices.

All entertainment devices must be switched off for both takeoff and landing.

2.4.11.2 Entertainment inhibit

The music input to the PAC24 uses the existing Speaker Power input from the KMA24-71. This pin should be removed even if music is not desired. However, if avionics power remains on Pin 7, there is the possibility of power ripple entering the system. The Music input can be deactivated from the front panel by press-

ing the NAV 1 and DME buttons for at least 3 seconds. The audio panel will then ignore any signal on this input, until the Music Off mode is toggled again.

2.4.12 Intercom expansion (P/N 11606 or 11606R)

The PAC24 contains a five-place intercom (pilot, copilot and up to three passengers). The passengers hear the same audio output as the copilot.

If a true “crew” mode is desired, or in applications where more intercom positions are needed, PS Engineering can provide intercom expansion units, such as the IntelliPAX, part number 11606 or 11606R (remote). These can add up to six additional stereo intercom stations, plus independent stereo music inputs.

DIP switches in the PAC24 *must* be configured to use the expansion. See § 2.2.4.

NOTE: The radio audio to the expansion unit is provided only by the audio panel connected. For example, the expansion unit connected to the copilot audio panel will **ONLY** receive audio selected by the copilot. The expansion unit connected to the pilot audio panel will **ONLY** receive audio selected by the pilot. Do not use the expansion Mono input for radio. (11606 Pin 22).

When a panel mounted IntelliPax (11606) expansion unit is used, only the expansion volume controls are active. The knob on the 11606, or the trimmer pots on the 11606R control passenger intercom volume.

NOTE: In installations where an expansion unit is NOT used, the passenger and copilot audio output is paralleled (J1, pin b). Therefore, unswitched audio will be heard by the passenger(s). Use an expansion unit, P/N 11606, or 11606R (remote) to isolate passenger audio from unswitched alert audio.

2.4.12.1 Standard PAC24 Versions, -0100 (J3, Pins 22, 23 and a)

Interface to the IntelliPAX (11606) expansion unit is through, pins 22 (audio input from expansion unit), 23 (audio output to expansion unit) and a (9 VDC expansion power).

These pins are shared with the microphone inputs; therefore the internal DIP switched must be correctly configured (see above).

2.4.13 CVR Output

As shipped from the factory, the PAC 24 has a CVR output on Pin 2, J3.

2.5 Adjustments

The PAC24 is factory adjusted to accommodate the typical requirements for most aircraft configurations. There are two adjustments however, that will allow the installer to tailor the speaker volume controls to suit specific functions. The PA volume adjusts the level of pilot and copilot mic audio in Public Address mode. The Master Volume adjusts the level of *all* audio presented to the cockpit speaker.

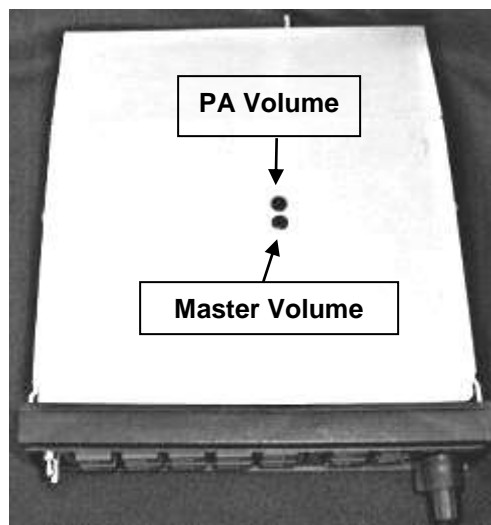

Figure 2-6- PAC24 Adjustments

2.6 Communications Antenna Installation Notes

For best results while in Dual installations or Split Mode (two communicates transceivers active at the same time), we recommend that the one COM communications antenna is located on top of the aircraft while the other communications antenna is installed on the bottom. Any antenna relocation must be accomplished in accordance with AC 43.13-2A, aircraft manufacturers' recommendations and FAA-approved technical data.

Warning:

It is probable that radio interference will occur in the split mode when the frequencies of the two aircraft radios are adjacent, and/or the antennas are physically close together. PS Engineering makes no expressed or implied warranties regarding the suitability of the PAC24 in Dual or Split Mode.

2.7 Post Installation Checkout

After wiring is complete, verify power is ONLY on pin 25 of the J3 and airframe ground on bottom connector pin A. Failure to do so will cause serious internal damage and void PS Engineering's warranty.

2.8 Unit Installation

To install the PAC24, gently slide the unit into the mounting rack until the hold-down screw is engaged. While applying gentle pressure to the face of the unit, tighten the 3/32" hex-head in the center of the unit until it is secure. DO NOT OVER TIGHTEN.

Warning: Do not over-tighten the lock down screw while installing the unit in tray.
Internal damage will result.

2.8.1 Operational Checkout

NOTE: The *IntelliVox*® is designed for ambient noise levels of 80 dB or above. Therefore some clipping may occur in a quiet cabin, such as without the engine running, in a hangar. This is normal.

1. Apply power to the aircraft and avionics.
2. Plug headsets into the pilot, copilot, and occupied passenger positions.
3. Verify fail-safe operation by receiving and transmitting on COM 1 from the pilot position, with the audio panel power off.
4. Switch on the unit by pressing the volume (VOL) knob.
5. Check intercom operation.
6. Push the COM 1 Xmt select button (lower row).
7. Verify that both of the **COM 1** buttons light. Verify that transmit button LED (Light Emitting Diode) near the mic selector is not blinking. If the LED is blinking, stop testing and troubleshoot the microphone PTT installation.
8. Verify proper transmit and receive operation from the copilot position, noting that the copilot PTT switch allows proper transmission on the selected transceiver. Verify that the COM 1 Xmt button blinks when transmitting.
9. Verify that pushing the **COM 2** button causes the button to illuminate, and the COM 2 receiver to be heard. Verify operation on COM 1 from the pilot position.
10. Repeat for other transceivers.
11. Press and hold the COM 1 Xmt button. While holding the COM 1 button, press the COM 2 Xmt button. This places the unit in "Split Mode;" Verify that the pilot can transmit and receive on COM 1, while the copilot transmits and receives on COM 2.
12. Verify proper operation of all receiver sources by selecting them using the appropriate button. The button illuminates to show which source is in use.
13. Switch the SPR control to SPR. Verify that all selected audio is heard in the cockpit speaker. Verify that the audio mutes when the mic is keyed.

PS Engineering
PAC24 Series Audio Selector Panel and Intercom System
Installation and Operator's Manual

14. Switch the SPR control to PA, and verify that the pilot mic is connected to the cabin or external speaker, (if installed).
15. Verify that the appropriate LED in the lower right side blinks when either push to talk is keyed.
16. Verify proper Intercom system operation in the **ALL**, **ISO** and **CREW** modes (see Table 3-1).
17. Verify that the audio selector panel system does not adversely affect any other aircraft system by systematically switching the unit on and off, while monitoring the other avionics and electrical equipment on the aircraft.

2.9 Final Inspection

Verify that the wiring is bundled away from all controls and no part of the installation interferes with aircraft control operation. Move all controls through their full range while examining the installation to see that no mechanical interference exists. Verify that the cables are secured to the aircraft structure in accordance with good practices, with adequate strain relief. Ensure that there are no kinks or sharp bends in the cables and coaxial cables. Verify that the cables are not exposed to any sharp edges or rough surfaces, and that all contact points are protected from abrasion.

Complete logbook entry, FAA Form 337, weight and balance computation and other documentation as required. Sample text for FAA Form 337, and instructions for continuing airworthiness can be found in Appendix F.

Return completed warranty registration application to PS Engineering.

Section III OPERATION

GENERAL INFORMATION

3.1 SCOPE

This section provides detailed operating instructions for the PS Engineering PAC24 High Performance Audio Selector Panel/Intercom Systems. Please read it carefully before using the equipment so that you can take full advantage of its capabilities.

This section is divided into three sections covering the basic operating areas of the PAC24 systems. They are transceiver selection, audio selector, and intercom.

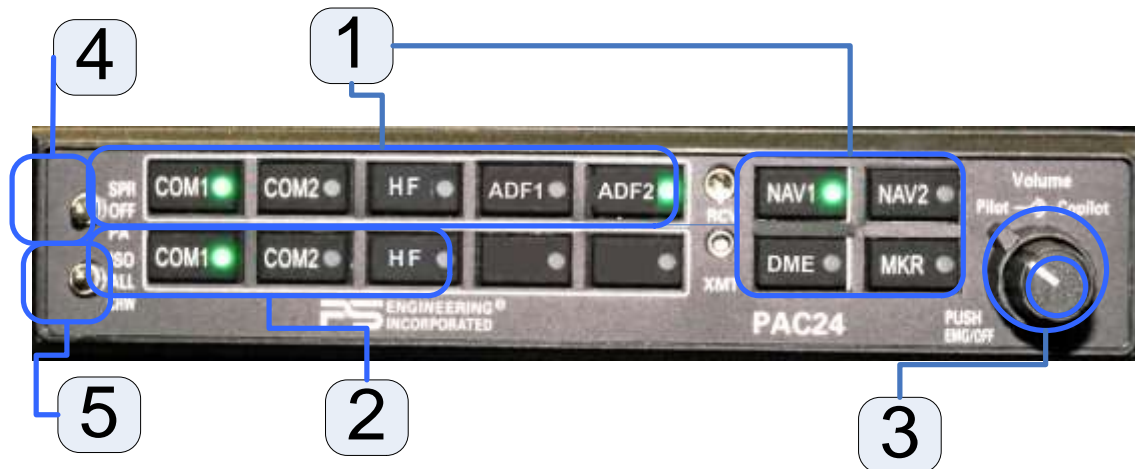

Figure 3-1 PAC24 -0123 front panel controls

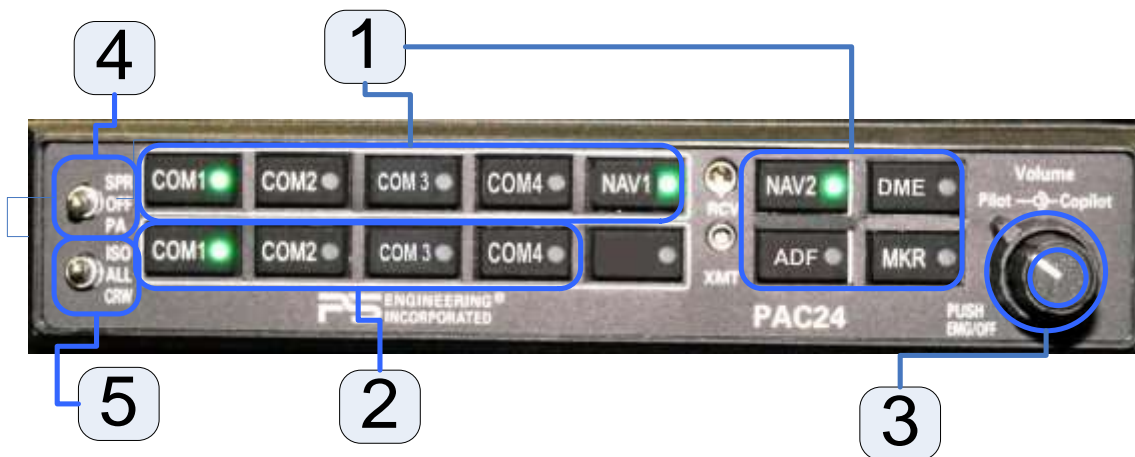

Figure 3-2 PAC24 -0700 Front Panel Controls

3.2 PAC24 Controls

- 1) Receiver Source Selection
- 2) Transmitter Selection
- 3) Volume / Power Controls
- 4) Speaker Selector
- 5) Intercom Mode Selector

3.3 Power Switch (3) (EMG-Fail Safe Operation)

Unit power is turned on and off by pushing the center (pilot) volume knob. The power switch controls the audio selector panel functions and intercom.

3.3.1 Single Panel Fail Safe Operation

In the OFF or "EMG" position, the pilot is connected directly to COM 1. This allows communication capability regardless of unit condition. Any time power is removed or turned OFF, the audio selector will be placed in the fail-safe mode.

3.3.2 Dual Panel Fail Safe Operation

In a dual installation, the PAC24 designated as Pilot's at installation, will default to COM 1. The audio panel designated as copilot will not operate in the off position. This prevents compromising the pilot's audio capability in the event of a dual audio panel problem.

3.4 Communications Selection (2)

There are 10 pushbuttons associated with the communications transceivers. The lower buttons control which transceiver is selected for transmit.

The PAC24 gives priority to the pilot's PTT. If the copilot is transmitting, and the pilot presses his PTT, the pilot's microphone will be heard over the selected com transmitter.

The PAC24 has an automatic selector mode. Audio from the transceiver selected by the Xmit button is automatically heard in the headsets and speaker (if selected). You can check this function by switching from COM 1 to COM 2 and watch the selected audio light on the selector change from COM 1 to COM 2. This ensures the pilot will *always* hear the audio from the transceiver he is transmitting on.

When switching from COM 1 to COM 2, while COM 2 audio had been selected, COM 1 audio will continue to be heard. This eliminates the pilot having to switch COM 1 audio back on, if desired.

When switching from COM 1 to COM 2 while COM 2 has NOT been selected, COM 1 audio will be switched off. In essence, switching the mic selector will not effect the selection of Com receiver audio. This is true of all transmitter selections.

NOTE: The radio audio to the expansion unit is provided only by the audio panel connected. For example, the expansion unit connected to the copilot audio panel will **ONLY** receive audio selected by the copilot. The expansion unit connected to the pilot audio panel will **ONLY** receive audio selected by the pilot. Do not use the expansion Mono input for radio. (11606 Pin 22).

3.4.1 Stuck Microphone Protection

The PAC24 has a function designed to prevent unintentional radio transmissions and blocked frequencies. After 35 seconds of continuous PTT on any input, the PTT line is lifted, and will remain unkeyed until the PTT input is recycled.

3.5 Receive Audio Selector (1)

Receiver audio is selected through 9 momentary push-button, backlit switches.

Because the microphone pushbutton selector switch controls what transceiver is being heard, you will always hear the audio from the transceiver that is selected for transmit.

The users can identify which receivers are selected by noting which of the green switch LEDs are illuminated. Push buttons labeled **Nav 1**, **Nav 2**, **MKR** (Marker), and **DME**, are momentary type switches. When one of these buttons is pressed, it will place the audio in the headphone or speaker output, and the LED will illuminate. Press the switch again and will remove that receiver from the audio.

If the aircraft is equipped with an ADF or DME, that audio is available through the DME button.

3.5.1 Speaker Amplifier (4)

The 3-position "SPR" switch controls the distribution of the audio in the cockpit or external (public address) speakers. In the up "SPR" position all selected audio is presented to the cockpit speaker. Unswitched audio, (autopilot disconnect, altimeter warning, etc.) will come through the speaker regardless of the speaker button position.

In PA, the primary (pilot) microphone audio is routed to the PA or external speaker (J3 pin B) when the PTT is active. The copilot mic input can continue to transmit on the selected radio.

3.5.2 Key "Click"

The PAC24 is equipped with a "click" function that provides an aural feedback to the user in addition to the tactile button push. This sound can be enabled or disabled by simultaneously holding the COM 1 and COM 2 buttons in for at least 5 seconds. Any person hearing the radios will also hear the key click.

Allow at least 20 seconds between turning the key click on and off.

3.6 Split Mode

The PAC24 has a flexible split mode, which allows one pilot to use one transceiver while the other can communicate on another. There are differences in the Split Mode in a single, or a dual audio panel installation.

Note:

Due to the nature of COM communications signals, and the size constraints in general aviation aircraft, it is probable that there will be some bleed-over in the Split mode, particularly on adjacent frequencies.

PS Engineering makes no warranty about the suitability of Split Mode in all aircraft conditions.

3.6.1 Split Mode, Dual Panel

In a dual panel installation, both pilots have access to any combination of transceivers. Because there is cross communication, each PAC24 knows the other unit's transmitter selection. The audio panel designated as "Pilot's" will have transmission priority over the panel designated as copilot's, when both panels are keyed for transmit on the same radio.

It is not necessary to activate the split mode by holding the buttons in a dual installation.

3.7 Intercom Operation

3.7.1 IntelliVox® VOX-Squelch

No adjustment of the *IntelliVox*® squelch control is necessary. There is no field adjustment. Through individual signal processors, the ambient noise appearing in all six microphones is constantly being sampled. Non-voice signals are blocked. When someone speaks, only their microphone circuit opens, placing their voice on the intercom.

The system is designed to block continuous tones, therefore people humming or whistling in monotone may be blocked after a few moments.

For consistent performance, any headset microphone **must** be placed within ¼-inch of your lips, preferably against them. (ref: *RTCA/DO-214, 1.3.1.1 (a)*).

It is also a good idea to keep the microphone out of a direct wind path. Moving your head through a vent air stream may cause the *IntelliVox*® to open momentarily. This is normal.

The *IntelliVox*® is designed to work with normal aircraft cabin noise levels (70 dB and above). It loves airplane noise! Therefore, it may not recognize speech and clip syllables in a quiet cabin, such as in the hangar, or without the engine running. This is normal.

For optimum microphone performance, PS Engineering recommends installation of a Microphone Muff Kit from Oregon Aero (1-800-888-6910). This will not only optimize VOX performance, but will improve the overall clarity of *all* your communications.

Table 3-1 Mic Muff™ Part Numbers

Manufacturer	Model	Mic Muff™ Part Number
Bose	Dynamic	90010
	Electret	90015
	M87 Dynamic	90020
David Clark	H10-30	90010
	H10-20, H10-40	90015
	H10-13.4	90015
Lightspeed	15K & 20K	90015
Peltor	7003	90010
	7004	90015
Pilot	11-20 & 11-90	90015
Sennheiser		90015
Telex	Airman 750	90015
	AIR3000	90010

3.7.2 Volume Control (3)

The volume control is a concentric knob. The inner knob adjusts the loudness of the intercom for the pilot (in single panel installation) and the outer knob controls copilot and passenger volume. It has no effect on selected radio levels or music input levels.

In dual installation, the inner knob controls the main volume (the person connected to the audio panel) and the outer knob controls the passengers.

When a panel mounted IntelliPax (11606) expansion unit is used, only the expansion volume controls are active. The knob on the 11606, or the trimmer pots on the 11606R control passenger intercom volume.

3.7.3 Intercom Modes (5)

The lower switch on the left side of the audio panel is a 3-position mode switch that allows the crew to tailor the intercom function to best meet the current cockpit situation.

3.7.3.1 Dual Installation Intercom Modes

ISO: (Up Position): The primary pilot connected to the PAC24 is isolated from the intercom and is connected only to the aircraft radio system. He will hear the selected aircraft radio reception (and sidetone during radio transmissions). The crewmember on the other audio panel will hear locally selected radio audio, passengers' intercom and entertainment, while passengers will hear the radio, intercom and entertainment.

ALL: (Middle Position): All parties will hear the aircraft radio and intercom. All will hear entertainment. During any radio or intercom communications, the music volume automatically decreases. The music volume increases gradually back to the original level after communications have been completed.

NOTE: The radio audio to the expansion unit is provided only by the audio panel connected. For example, the expansion unit connected to the copilot audio panel will **ONLY** receive audio selected by the copilot. The expansion unit connected to the pilot audio panel will **ONLY** receive audio selected by the pilot. Do not use the expansion Mono input for radio. (11606 Pin 22).

CREW (Down Position): Pilot and copilot are connected on one intercom channel and have exclusive access to the locally selected aircraft radios. They may also listen to Entertainment. Because the single panel, non-expansion PAC24 (and KMA 24H) uses the same output for the copilot and passenger, "Crew" mode is not possible (Unless expansion module, p/n 11606 is used)

3.7.4 Entertainment Input

The audio selector panel has provisions for one entertainment input device in each audio panel. The volume control does not affect music level.

Anytime a person speaks on the intercom, or there is radio traffic, the music will be muted. It will return gradually, through the use of SoftMute™ circuitry.

The SoftMute™ can be defeated for a “Karaoke Mode” (music does not mute) by pressing the NAV1 and NAV2 buttons simultaneously for at least 3 seconds. Pressing the buttons again will reactivate SoftMute™.

While in the ISO (Isolate) mode, the non-isolated crewmember and passengers will hear entertainment. When in the ALL mode, all persons will hear the entertainment source.

3.7.4.1 Music Off

Music Off mode may be selected in cases where a music input is not connected, or in use, but audio noise can be heard due to other loads or cross-talk in the system.

Music can be inhibited completely by pressing NAV1 and DME (or ADF) for at least 3 seconds. Music Off will override karaoke mode

3.7.4.2 Hot Mic /IntelliVox® squelch disable

For testing purposes, the Intellivox® intercom squelch can be turned off, and the microphones become always hot (open). Press TEL Receive & Nav 1 buttons for at least 3 seconds to enable/disable this hot mic intercom mode.

Section IV- Warranty and Service

4.1 Warranty

In order for the factory warranty to be valid, the installations in a certified aircraft must be accomplished by an FAA-certified avionics shop and authorized PS Engineering dealer. If the unit is being installed by a non-certified individual in an experimental aircraft, a factory-made harness must be used for the warranty to be valid.

PS Engineering, Inc. warrants this product to be free from defect in material and workmanship for a period of three (3) years from the date of sale.

In the event of a problem, contact the authorized PS Engineering Dealer where the product was purchased for assistance. Units will not be accepted by PS Engineering for repair without a Return Authorization.

During the first **twelve (12) months** of the warranty period, PS Engineering, Inc., at its option, will send a replacement unit at our expense if the unit should be determined to be defective after consultation with the PS Engineering dealer who sold the unit and a PS Engineering, Inc. factory technician.

For the remaining **twenty-four (24) months**, three-year warranty period, PS Engineering, Inc., at its option, will send a replacement unit at the customers expense if the unit should be determined to be defective after consultation with an authorized PS Engineering dealer.

All transportation charges for returning the defective units are the responsibility of the purchaser. All domestic transportation charges for returning the exchange or repaired unit to the purchaser will be borne by PS Engineering, Inc. The risk of loss or damage to the product is borne by the party making the shipment, unless the purchaser requests a specific method of shipment. In this case, the purchaser assumes the risk of loss.

This warranty is not transferable. Any implied warranties expire at the expiration date of this warranty. PS Engineering SHALL NOT BE LIABLE FOR INCIDENTAL OR CONSEQUENTIAL DAMAGES. This warranty does not cover a defect that has resulted from improper handling, storage or preservation, or unreasonable use or maintenance as determined by us. This warranty is void if there is any attempt to disassemble this product without factory authorization. This warranty gives you specific legal rights, and you may also have other rights, which may vary from state to state. Some states do not allow the exclusion of limitation of incidental or consequential damages, so the above limitation or exclusions may not apply to you.

All items repaired or replaced under this warranty are warranted for the remainder of the original warranty period. PS Engineering, Inc. reserves the rights to make modifications or improvements to the product without obligation to perform like modifications or improvements to previously manufactured products.

4.2 Factory Service

Call PS Engineering, Inc. at (865) 988-9800 before you return the unit. This will allow the service technician to provide any other suggestions for identifying the problem and recommend possible solutions.

After discussing the problem with the technician and you obtain a Return Authorization Number, ship product to:

PS Engineering, Inc.
Attn: Service Department
9800 Martel Rd
Lenoir City, TN 37772
(865) 988-9800 FAX (865) 988-6619
Email: support@ps-engineering.com

Units that arrive without an RMA number, or telephone number for a contact will be returned rejected. PS Engineering is not responsible for items sent via US Mail.

Appendix A – Installation Drawing

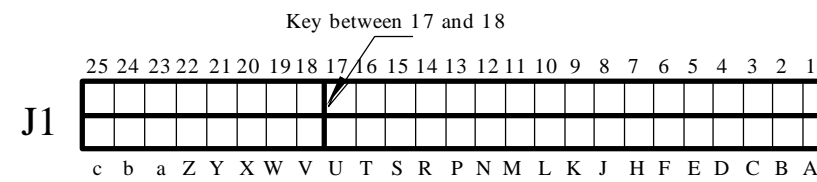
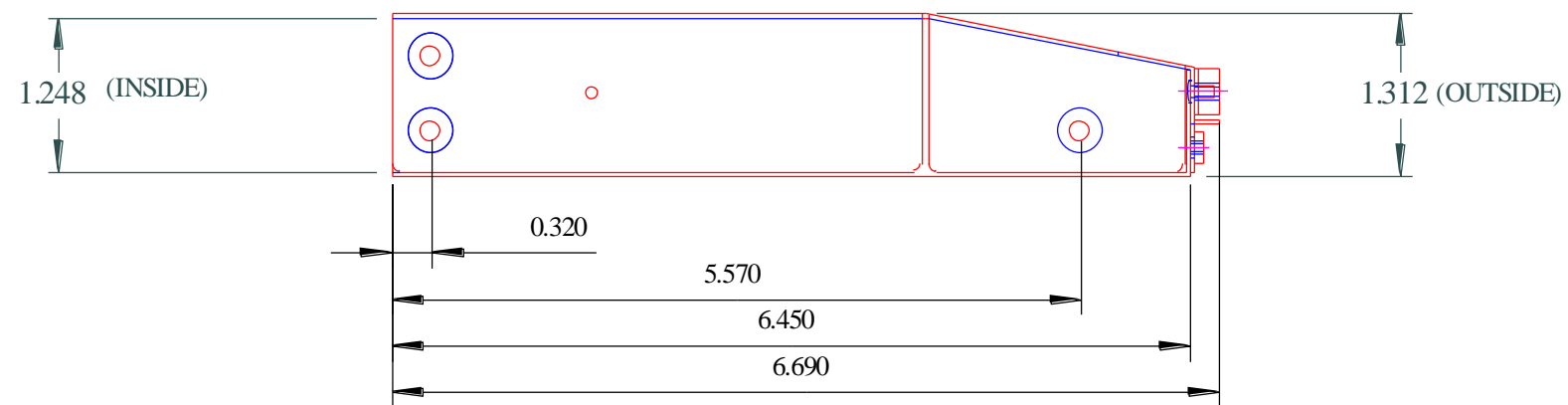
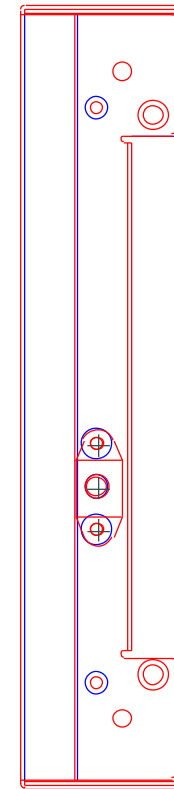
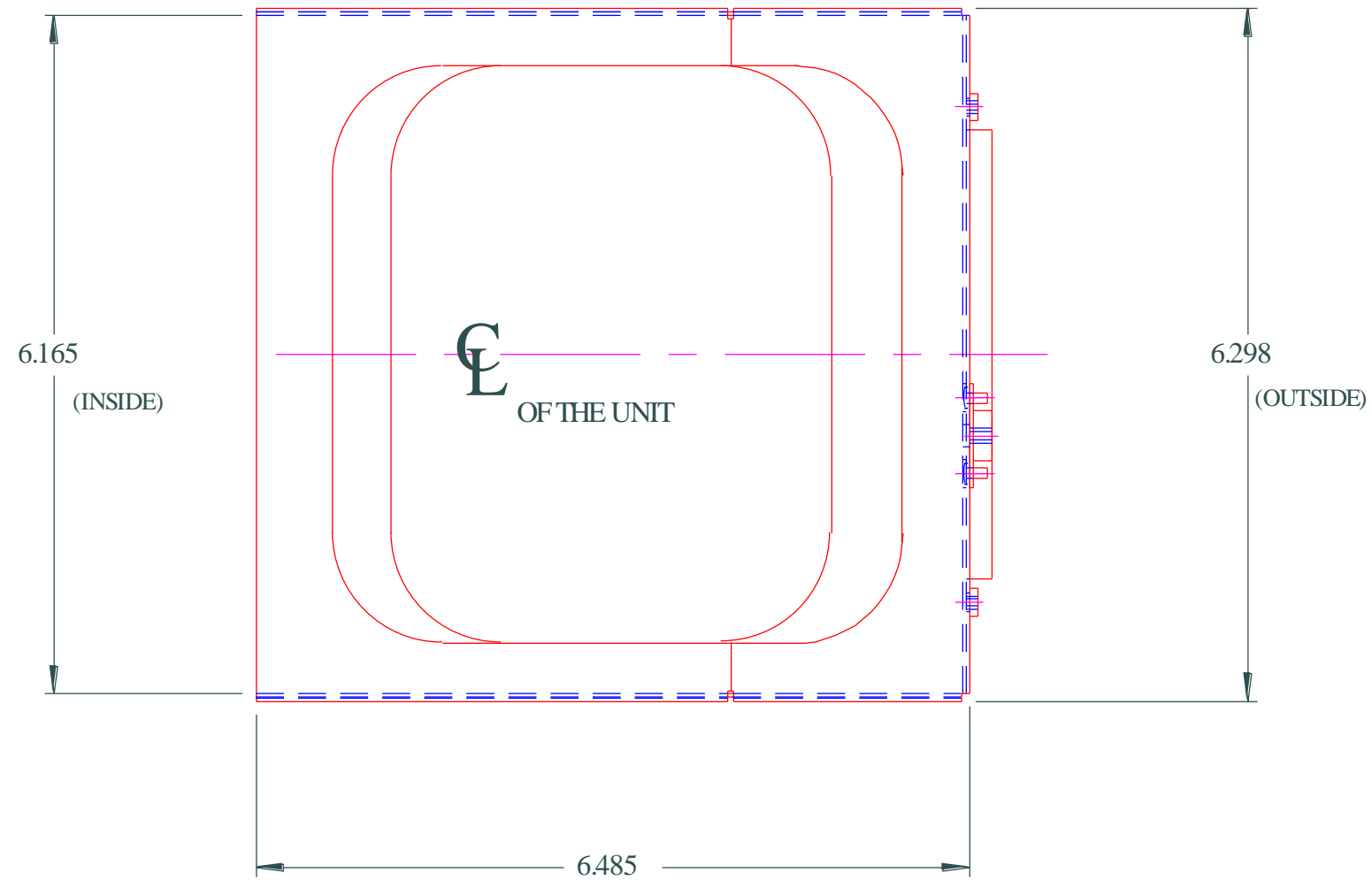

Rear Connector (Viewed from front)

Appendix B Single Unit -0700 Interconnect Wiring

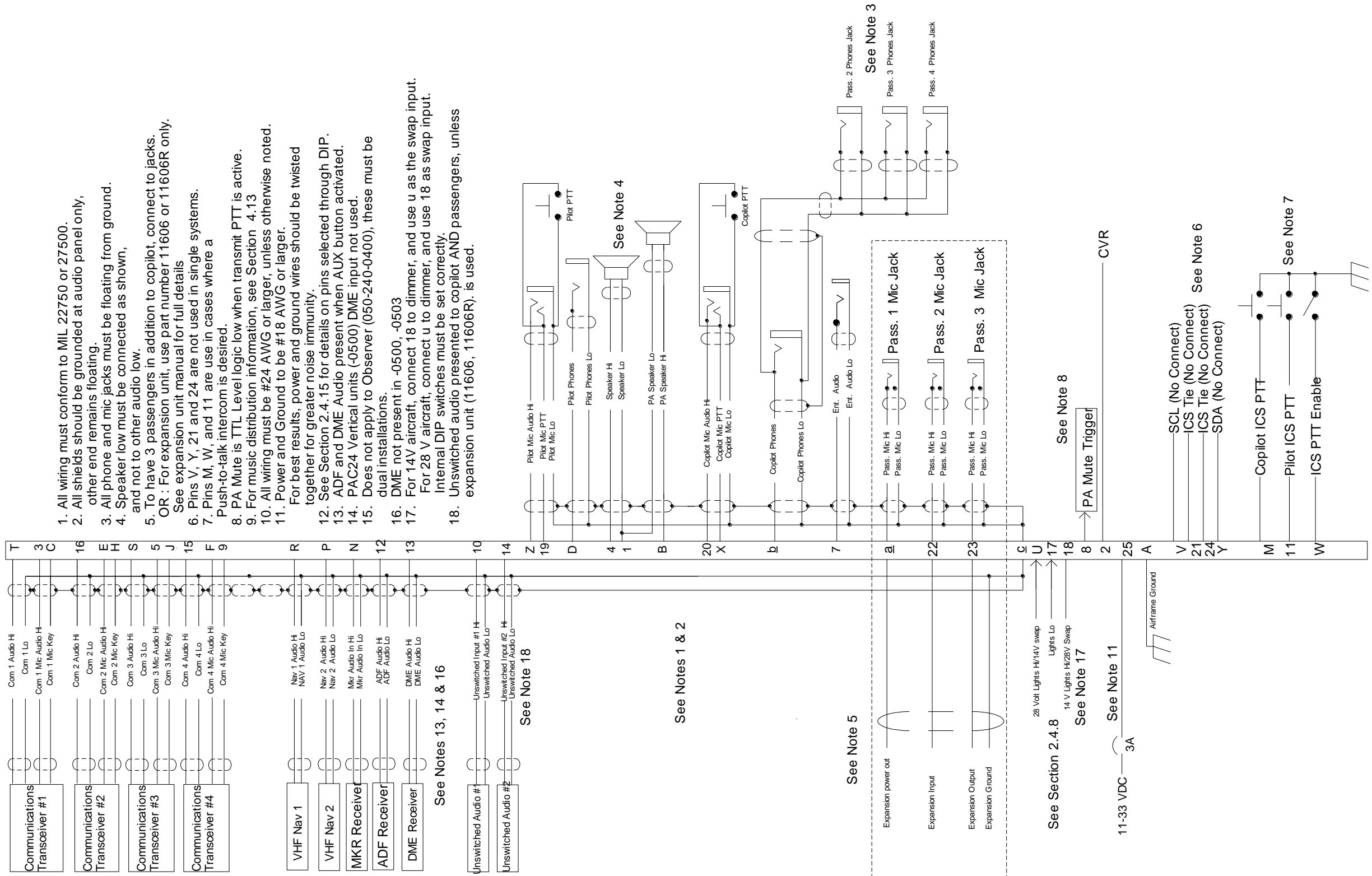

1. All wiring must conform to MIL 22750 or 27500.
2. All shields should be grounded at audio panel only, other end remains floating.
3. All phone and mic jacks must be floating from ground.
4. Speaker low must be connected as shown, and not to other audio low.
5. To have 3 passengers in addition to copilot, connect to jacks.
 OR : For expansion unit, use part number 11606 or 11606R only.
 See expansion unit manual for full details
6. Pins V, Y, 21 and 24 are not used in single systems.
7. Pins M, W, and 11 are use in cases where a Push-to-talk intercom is desired.
8. PA Mute is TTL Level logic low when transmit PTT is active.
9. For music distribution information, see Section 4.13
10. All wiring must be #24 AWG or larger, unless otherwise noted.
11. Power and Ground to be #18 AWG or larger.
 For best results, power and ground wires should be twisted together for greater noise immunity.
12. See Section 2.4.15 for details on pins selected through DIP.
13. ADF and DME Audio present when AUX button activated.
14. PAC24 Vertical units (-0500) DME input not used.
15. Does not apply to Observer (050-240-0400), these must be dual installations.
16. DME not present in -0500, -0503
17. For 14V aircraft, connect 18 to dimmer, and use u as the swap input.
 For 28 V aircraft, connect u to dimmer, and use 18 as swap input.
 Internal DIP switches must be set correctly.
18. Unswitched audio presented to copilot AND passengers, unless expansion unit (11606, 11606R) is used.

See Notes 13, 14 & 16

See Note 18

See Notes 1 & 2

See Note 5

See Note 3

See Section 2.4.8

See Note 8

PA Mute Trigger

See Note 17

See Note 11

11-33 VDC 3A

Airframe Ground

SCL (No Connect)
 ICS Tie (No Connect)
 ICS Tie (No Connect)
 SDA (No Connect)

See Note 6

Copilot ICS PTT
 Pilot ICS PTT
 ICS PTT Enable

See Note 7

Appendix B Dual Interconnect Radio Wiring (-0123 units)

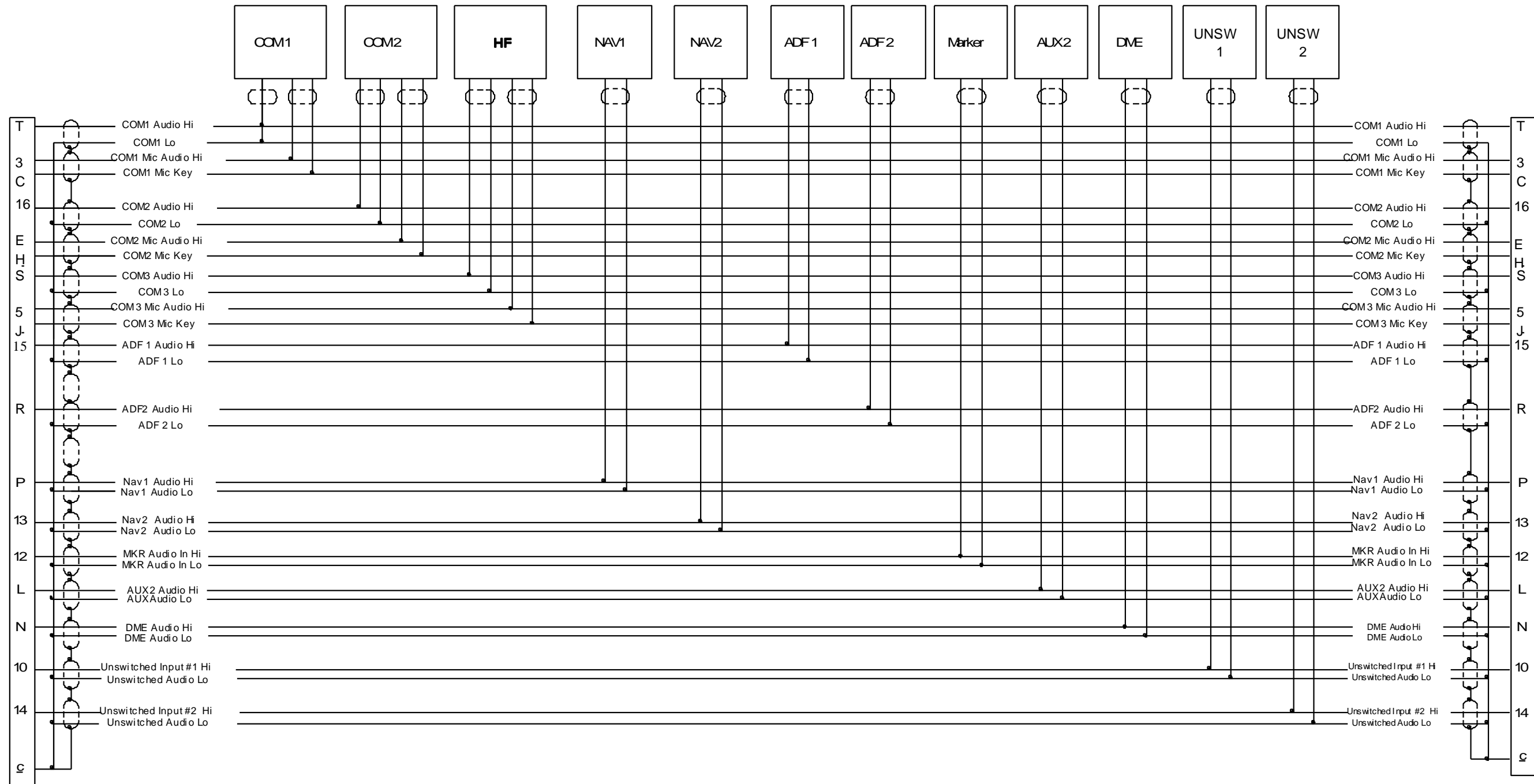

Appendix B Dual Interconnect Radio Wiring (-0700) units

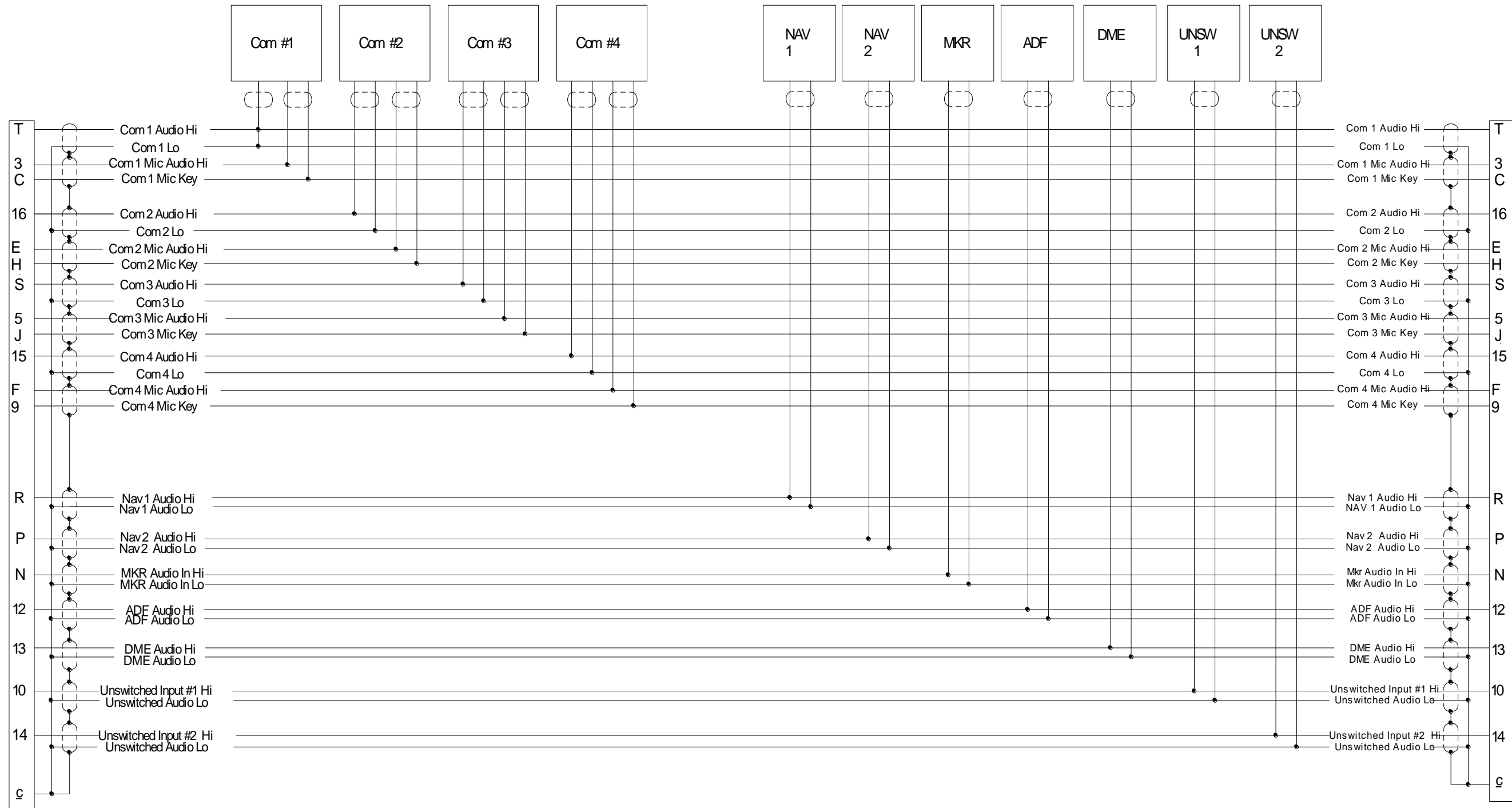

8.1 Dual PAC24 Crew Audio Wiring, Standard (-0123, -0700) Units

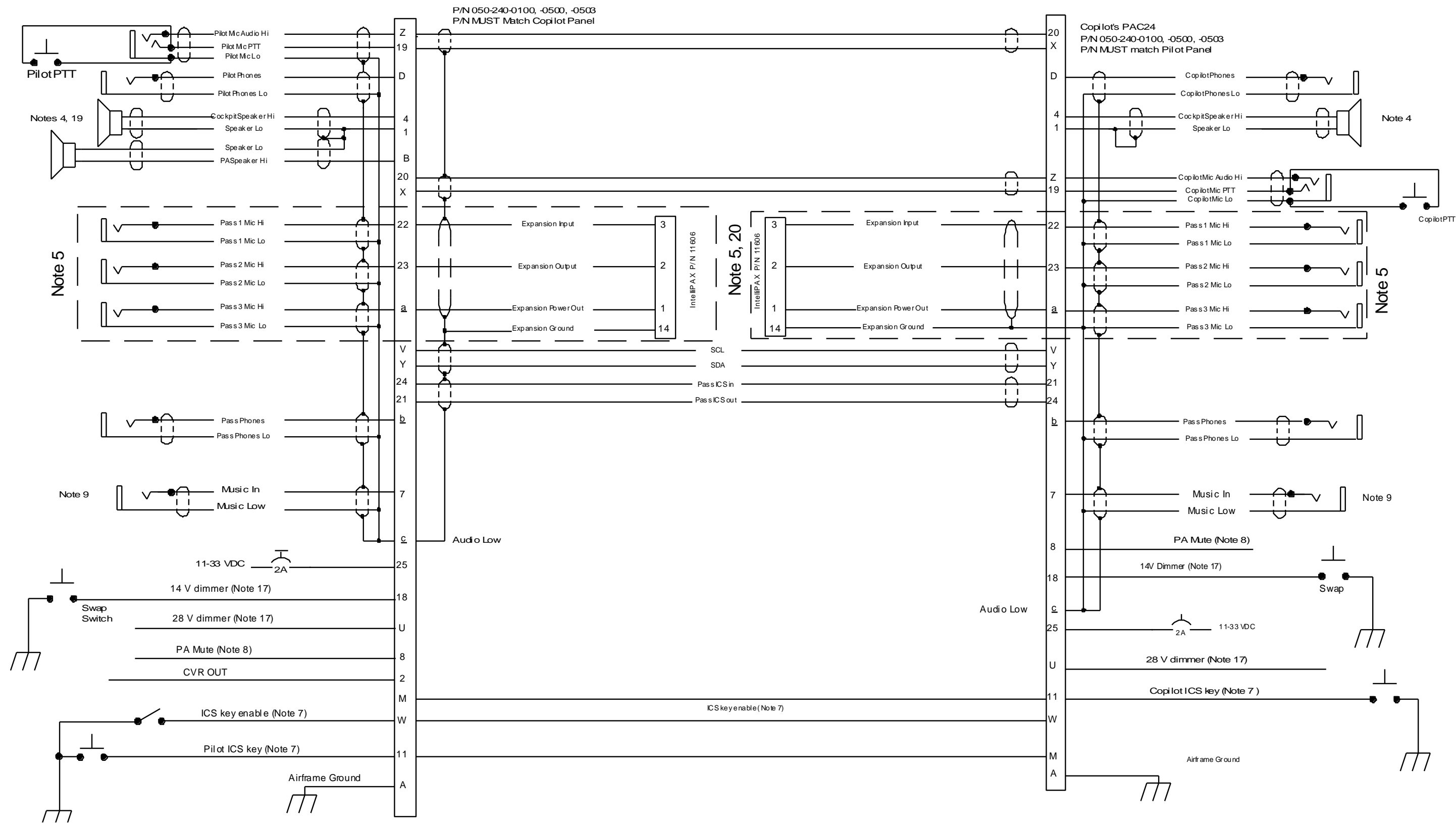

Appendix C- Instructions for FAA Form 337 and continuing airworthiness

9.1 Instructions for FAA Form 337, Audio Panels

One method of airworthiness approval is through an FAA Form 337, *Major Repair and Alteration (Airframe, Powerplant, Propeller, or Appliance)* In the case of the PAC24, you may use the following text as a guide.

Installed audio selector and 6-place intercom, PS Engineering PAC24, part number 050-240- (XXX) in (location) at station _____. Installed per *AC43.13-2B, Chapter 2*, Installed per PS Engineering *Installation Operators Manual* p/n 200-240-(XXXX), revision (), dated ().

This unit is FAA-Approved under TSO C50c for audio amplifiers, and meets appropriate environmental qualifications outlined in RTCA DO-160D as appropriate or this aircraft.

Interface to existing aircraft radios in accordance with installation manual and in compliance with practices listed in *AC43.13-2B, Chapter 2*. All wires are Mil-Spec 22759 or 27500. Connection to aircraft dimmer bus is _____. Power is supplied to the unit through a 3A circuit breaker (type and part number), and total electrical load does not exceed ____% of the electrical system capacity with the PAC24 added.

Aircraft equipment list, weights and balance amended. Compass compensation checked. A copy of the operation instructions, contained in PS Engineering document 200-240-(), revision (), dated (), is placed in the aircraft records. All work accomplished listed on Work Order _____.

9.2 Instructions for Continuing Airworthiness, Audio Panels

Sample ICA Checklist for PS Engineering Audio Panels:

Section	Item	Information
1	Introduction	Installation of audio control panel with integrated marker beacon receiver and intercommunications system.
2	Description	Installation as described in manufacturer's installation manual referenced on FAA Form 337, including interface with other avionics audio as required.
3	Controls	See installation and operator's guide referenced on FAA Form 337.
4	Servicing	None Required
5	Maintenance Instructions	On Condition, no special instructions
6	Troubleshooting	In the event of a unit problem, place the unit into "off," "fail-safe" and/or "emergency" mode. This allows pilot communications using COM 1. Follow checkout instructions in the installation manual referenced on the FAA Form 337. For a specific unit fault, contact the manufacturer at (865) 988-9800 for special instructions.
7	Removal and replacement information	<u>Removal:</u> Using a 3/32" Allen-head wrench, carefully unscrew the locking screw located in the center of the unit. While turning the wrench CCW, gently pull on the EDGES of the bezel until the unit is free from the mounting tray. <u>Installation:</u> Engage the locking screw at the back. Turn the locking screw CW, while applying slight pressure to the edges of the bezel. Do not over tighten!
8	Diagrams	Not applicable
9	Special Inspection Requirements	Not Applicable
10	Protective Treatments	Not Applicable
11	Structural Data	Not Applicable
12	Special Tools	None
13	Not Applicable	Not Applicable
14	Recommended Overhaul Periods	None
15	Airworthiness Limitations	Not Applicable
16	Revision	To be determined by installer

Appendix D – RTCA DO160D (EUROCAE ED-14) Environmental Qualification Form

Audio Selector Panel/Intercom

Part Number: 050-240-0XXX

FAA TSO Number: C50c, Class A,

Manufacturer: PS Engineering Incorporated 9800 Martel Road Lenoir City TN 37772

Conditions	Section	Conducted Tests
Temperature and Altitude	4.0	Equipment tested to CAT B1
Low Temperature	4.5.1	-55° C Survival, -20°C Low Operating (B1)
High Temperature	4.5.2	+85°C Survival, +70°C High Short Time Operating
In-flight Loss of Cooling	4.5.4	Not Applicable, no cooling required
Altitude	4.6.1	25,000' unpressurized (B1)
Decompression	4.6.2	Not Applicable
Overpressure	4.6.3	Not Applicable
Temperature variation	5.2	Equipment tested to Category C
Humidity	6.0	Equipment tested to Category A
Operational Shock and Crash Safety	7.0	Equipment tested Category B
Vibration	8.0	Equipment tested to Category G & M
Explosion	9.0	Category X, not tested
Waterproofness	10.0	Category X, not tested
Fluids Susceptibility	11.0	Category X, not tested
Sand and Dust	12.0	Category X, not tested
Fungus	13.0	Category X, not tested
Salt Spray	14.0	Category X, not tested
Magnetic Effect	15.0	Equipment tested to Category Z
Power input	16.0	Equipment tested to Category B
Voltage Spike	17.0	Equipment tested to Category B
Audio Frequency Susceptibility	18.0	Equipment tested to Category B
Induced Frequency Susceptibility	19.0	Equipment tested to Category A
Radio Frequency Susceptibility	20.0	Equipment tested to Category T
Radio Frequency Emission	21.0	Equipment tested to Category M
Lightning Induced Transient Susceptibility	22.0	Equipment tested to Category XXE2
Lightning Direct Effects	23.0	Category X, not tested
Icing	24.0	Category X, not tested
Electrostatic Discharge	25.0	Category X, not tested